

Dräger X-plore® Rd40 Filter

Whether used in chemical industry or automobile industry, shipbuilding, metal processing industry or by public utility services – for decades Dräger respiratory protection filters have been a synonym for experience and safety worldwide. They clean breathable air from contaminants in a low-cost and effective manner.

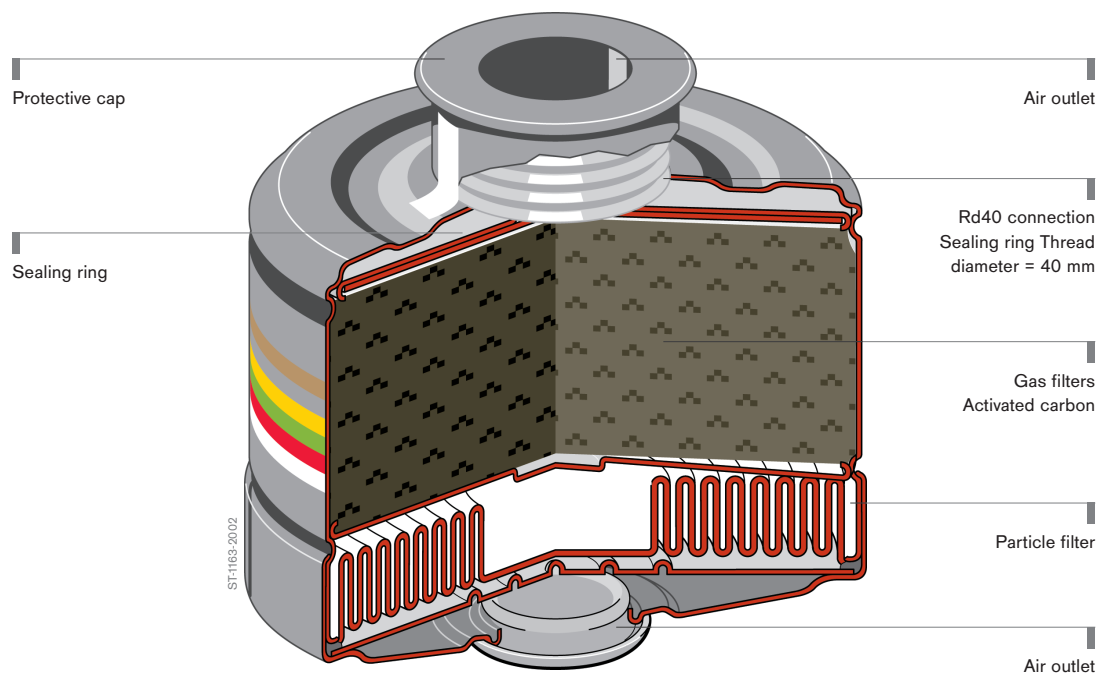

Benefits

Broad filter range

The X-plore Rd40 filter series offers various filter types for major applications and protects against many hazardous substances – from phosphine to tear gas to particulates.

Long life

The gas filters and combination filters have a shelf-life of 6 years and the particle filters a shelf life of 12 years from date of manufacture.

Resealable individual packaging

The filters are packed individually to ensure optimum protection of the unused filter. For storage, the packaging is resealable.

Supporting filter selection

The Dräger VOICE database of hazardous substances offers comprehensive support for selecting filters (www.draeger.com/voice).

Aluminum housing

The aluminum housing ensures that any damage to the filter is easily detected, therefore providing extra security.

CE marking

All filters are CE-marked in accordance with EN 14387 and/or EN 143.

Rd40 thread connection

The filters are suitable for use with half and full face masks with standard thread connection Rd40 according to EN 148-1.

Technical Data

FILTER COLOUR CODING

| Color | Filter Type | Main field of application |
|--------|-------------|--|
| Brown | AX | Gases and vapors of organic compounds with boiling point ≤ 65 °C |
| Brown | A | Gases and vapors of organic compounds with boiling point > 65 °C |
| Grey | B | inorganic gases and vapors, e.g. chlorine, hydrogen sulphide, hydrogen cyanide |
| Yellow | E | Sulphur dioxide, hydrogen chloride |
| Green | K | Ammonia |
| Black | CO | Carbon monoxidized |
| Red | Hg | Mercury vapor |
| Blue | NO | Nitrous gases, including nitrogen monoxide |
| Orange | Reactor | Radioactive iodine including radioactive methyl iodide |
| White | P | Particles |

Ordering Information

| Filter type | Order code |
|--|------------|
| Particle Filters | |
| 1140 P3 R (incinerable) also approved as filter TH/M3 P SL R (EN 12941/12942) for Dräger X-plore® 7500 | 67 38 932 |
| 1140 P3 R (incinerable), bulk pack also approved as filter TH/M3 P SL R (EN 12941/12942) for Dräger X-plore® 7500 | 67 32 974 |
| Gas Filters | |
| 940 A2 | 67 38 855 |
| 940 A2B2 | 67 38 779 |
| 1140 AX | 67 38 863 |
| 1140 AXB2* | 67 38 782 |
| 940 K2 | 67 38 856 |
| 940 A2B2E2K1 | 67 38 802 |
| 1140 A2B2E2K2* | 67 38 804 |
| Combination Filters | |
| 940 A2 P2 R D | 67 38 857 |
| 1140 A2 P3 R D also approved as filter TH/M3 A2 P SL R (EN 12941/12942) for Dräger X-plore® 7500 | 67 38 860 |
| 940 A2B2 P2 R D | 67 38 780 |
| 1140 A2B2 P3 R D also approved as filter TH/M3 A2B2 P SL R (EN 12941/12942) for Dräger X-plore® 7500 | 67 38 783 |
| 1140 AX P3 R D | 67 38 862 |
| 940 K2 P2 R D | 67 38 858 |
| 940 A2B2E2K1 P2 R D | 67 38 803 |
| 1140 A2B2E2K1 Hg P3 R D | 67 38 815 |
| 1140 A2B2E2K2 Hg P3 R D* also approved as filter TH/M3 ABEK2 Hg P SL R (EN 12941/12942) for | 67 38 797 |

Ordering Information

Dräger X-plore® 7500

| | |
|--|-----------|
| 1140 A1B2E2K1 Hg NO P3 R D / CO 20 P3 R D* | 67 38 801 |
| 1140 A2B2E2K2 Hg NO P3 R D / CO 20 P3 R D* | 67 38 814 |

Special Filters

| | |
|---|-----------|
| 1140 A2 P3 R D / Reactor/Nuclear P3 R D | 67 38 871 |
|---|-----------|

*Only use in conjunction with full face masks as filter weight > 300 g

Marking D: for successfully passed dolomite test

Marking R: Reusable – protection for more than one work shift

CORPORATE HEADQUARTERS

Drägerwerk AG & Co. KGaA
Moislinger Allee 53–55
23558 Lübeck, Germany
www.draeger.com

REGION EUROPE CENTRAL AND EUROPE NORTH

Dräger Safety AG & Co. KGaA
Revalstraße 1
23560 Lübeck, Germany
Tel +49 451 882 0
Fax +49 451 882 2080
info@draeger.com

REGION EUROPE SOUTH

Dräger Safety France SAS
25, rue Georges Besse
92182 Antony Cedex
Tel +33 1 46 11 56 00
Fax +33 1 40 96 97 20
europe.south@draeger.com

REGION MIDDLE EAST, AFRICA

Dräger Safety AG & Co. KGaA
Branch Office
P.O. Box 505108
Dubai, United Arab Emirates
Tel +971 4 4294 600
Fax +971 4 4294 699
contactuae@draeger.com

REGION ASIA PACIFIC

Draeger Safety Asia Pte Ltd
25 International Business Park
#04-20/21 German Centre
Singapore 609916
Tel +65 6308 9400
Fax +65 6308 9401
asia.pacific@draeger.com

REGION CENTRAL AND SOUTH AMERICA

Dräger Panama S. de R.L.
Complejo Business Park,
V tower, 10th floor
Panama City
Tel +507 377 9100
Fax +507 377 9130
contactcsa@draeger.com

Locate your Regional
Sales Representative at:
www.draeger.com/contact

